

Fig. 137: Standard U-bolt

Fig. 137S*: Special U-bolt (non-standard)

U-Bolts

Size Range: 1/2" through 36"

Material: Carbon steel U-bolt and four finished hex nuts

Finish: Plain or Fig. 137: Zinc Plated (Hot-Dip Galvanized optional) or Fig. 137S: Hot-Dip Galvanized (HDG not available for rod size 1/4". Stainless steel is offered as an alternative.)

Service: Recommended for support, or guide of heavy loads; often employed in power, process plant and marine service.

Approvals: Complies with Federal Specification A-A-1192A (Type 24), WW-H-171-E (Type 24), ANSI/MSS SP-69 and MSS SP-58 (Type 24).

Ordering Fig. 137: Specify pipe size x rod size (e.g., 6 x 5/8), figure number, name. U-bolt will be furnished with longer tangents D or with longer threads E if so required and ordered. If hex nuts are not required, specify "without hex nuts".

Ordering Fig. 137S: Specify figure number, name, material specification, dimensions A, B, C, D, and E, and "with hex nuts" or "without hex nuts".

Note: The acceptability of galvanized coatings at temperatures above 450°F is at the discretion of the end user.



FIG. 137: DIMENSIONS (IN) • LOADS (LBS) • WEIGHTS (LBS) ■										
Pipe Size	Rod Size A	Max Normal Load		650° F Max Side Load	Wt.	B	C	D	E	F
		650° F	750° F							
1/2	1/4	580	454	145	0.11	15/16	13/16	23/4	21/8	25/16
3/4					0.12	11/8	13/8			27/32
1					0.12	13/8	15/8			23/32
1 1/4	3/8	1,460	1,144	365	0.28	111/16	21/16	27/8	21/2	21/32
1 1/2					0.30	2	23/8	3		21/16
2					0.33	27/16	213/16	31/4		21/16
2 1/2	1/2	2,700	2,114	675	0.73	215/16	31/16	33/4	3	25/16
3					0.78	33/16	41/16	4		21/4
3 1/2					0.84	41/16	49/16	41/4		21/4
4					0.90	49/16	51/16	41/2		27/32
5					1.0	55/8	61/8	5		213/16
6	5/8	4,320	3,382	1,080	2.0	63/4	73/8	61/8	31/2	213/16
8					2.3	83/4	93/8	71/8		3
10					4.9	107/8	115/8	83/8		3
12	7/8	9,960	7,016	2,240	7.7	127/8	133/4	95/8	41/4	31/4
14					8.3	141/8	15	101/4		31/4
16					9.2	161/8	17	111/4		31/4
18					13.5	181/8	191/8	125/8		31/4
20					14.6	201/8	211/8	135/8		31/4
24	1	11,800	9,240	-	16.9	241/8	251/8	155/8	43/4	35/8
30					19.1	301/8	311/8	185/8		35/8
36					23.2	361/8	371/8	215/8		35/8

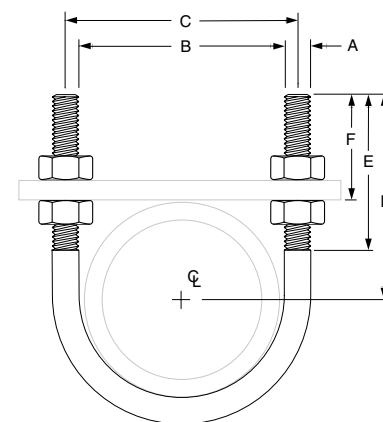

*When the combination of a normal load and a side load occurs, a straight line interaction formula may be used to determine if the Fig. 137 is still within the allowable stress range:

$$P_n/P_{na} + P_s/P_{sa} \leq 1$$

Where:

P_n = actual applied normal load;

P_{na} = allowable normal load for the Fig. 137;

P_s = actual applied side load;

P_{sa} = allowable side load for the Fig. 137

Nuts must be snug tight in installation to achieve side loads shown.

■ Loads, weights and dimensions shown do not apply for Fig. 137S. Max load rating for carbon steel is based on 2 x load rating for rod. Max load rating for stainless steel is 0.85 times the maximum stated load ratings listed above.

PROJECT INFORMATION		APPROVAL STAMP	
Project:		<input type="checkbox"/> Approved	
Address:		<input type="checkbox"/> Approved as noted	
Contractor:		<input type="checkbox"/> Not approved	
Engineer:		Remarks:	
Submittal Date:			
Notes 1:			
Notes 2:			